

VAV flow regulator

RAVAV



Description

The RAVAV regulator is dedicated for forced ventilation systems and is an important component for installations with variable air flow.

The regulator casing is made of Z 275 galvanized sheet. Optionally, it is possible to use the 1.4301 stainless steel to build the casing. Casing sides with factory-installed EPDM rubber gaskets ensure tight connection to ventilation ducts. Inside the casing, the adjusting damper is also insulated (depending on the control mechanism). The servomotor is installed on the control unit casing so as to allow for thermal insulation of the system. The regulator is also available in the version with pre-installed 50 mm insulation and a galvanised steel shield.

The measuring system based on aluminum impact pressure tubes and pressure relieve stub pipes ensures reliable measuring of the air flow.

Sensor, control unit and servomotor are integrated in one device. The servomotor adjusts the damper position, the control unit compares the current air flow rate with the set value and the sensor turns the differential pressure value into electric signal.

It is possible to use separate control mechanism components to achieve shorter operating times of the actuator or to use the sensor in an aggressive environment.

Version: 009v4/11/21/PG.

Marking example

Product code: **RAVAV-aaa-bbb-ccc-ddd**

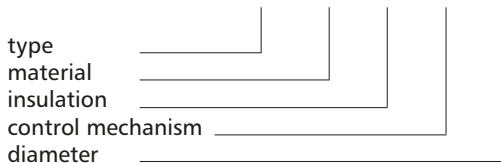

Dimensions

Default: not insulated

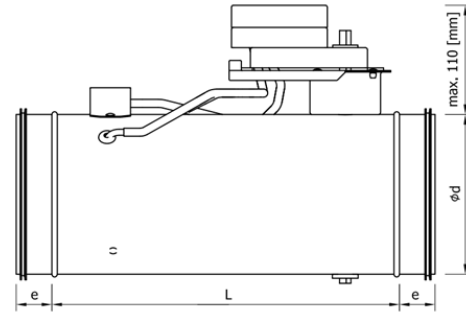

Version insulation with external shield, thickness: 50 mm

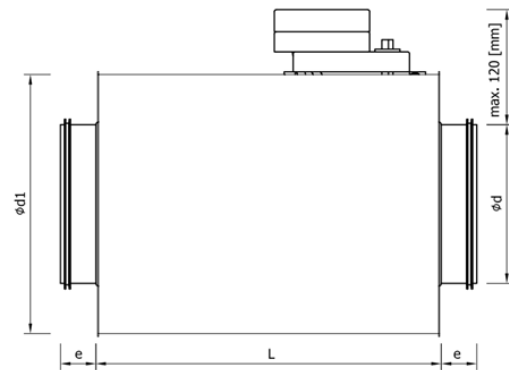

DN	L [mm]	e [mm]	d [mm]	d1 [mm]	weight RAVAV [kg]	weight RAVAV-I [kg]
100	338	36	99	200	1,4	2,8
125	338	36	124	224	1,7	3,4
160	338	36	159	250	2,1	4,2
200	338	36	199	300	2,3	4,5
250	528	36	249	355	4,0	8,0
315	528	36	314	400	5,0	9,9
400	490	55	399	500	7,6	15,2
500	490	75	496	600	-	-
630	490	75	626	710	-	-

VAV flow regulator

RAVAV

Ordering options

- Material:**
 RAVAV-... - default: galvanised steel
 RAVAV-K-... - 1.4301/304
- Insulation:**
 RAVAV-... - default: not insulated
 RAVAV-I-... - insulation with external shield, thickness: 50 mm
 RAVAV-K-I-... - steel 1.4301/304, insulation with external shield, thickness 50 mm
- Control mechanism:**
 RAVAV-... - Belimo servomotor, series Compact LMV-D3... no internal insulation for Ø400-630; (default)
 RAVAV-NM - Belimo servomotor, series Compact NMV-D3... internal insulation for Ø400-630
 RAVAV-G - Gruner servomotor, series 227VM
 RAVAV-MOD - Modbus RTU servomotor
 RAVAV-KNX - KNX servomotor

Diameter:
 Regulators are available in the range of Ø100-630mm.

- *Additional options:**
 V_{min} - flow minimum [m³/h] (range 0-100% V_{nom})
 V_{max} - flow maximum [m³/h] (range 0-100% V_{nom})
 0-10 (or different) - control signal (default 2-10 V)

*Please specify non-standard settings, when placing an order.

Code example:
 RAVAV-K-I-KNX-315

The manufacturer reserves the right to make changes.

Characteristics

- High air flow measurement accuracy (,
- The insulation rating of the adjusting damper is class 4 as per EN-1751:1998 (optional),
- Casing tightness is class C as per EN-1751:1998,
- Operating temperature range from 0 to 50 [°C],
- Differential pressure range from 50 to 1000 [Pa],
- Possibility to measure current air flow parameters using external micromanometers.

Recommended minimum distances

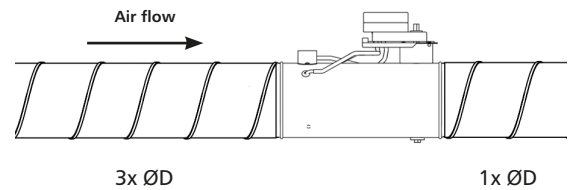

Operating diagram

Sensor, control unit and servomotor are integrated in one device. The servomotor adjusts the damper position, the control unit compares the current air flow rate with the set value and the sensor turns the differential pressure value into electric signal.

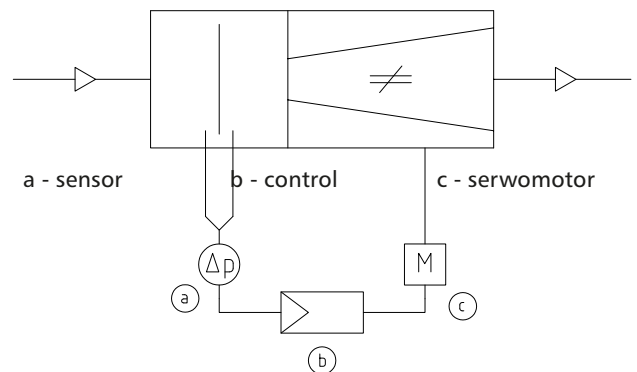

VAV flow regulator

RAVAV

Pressure drops

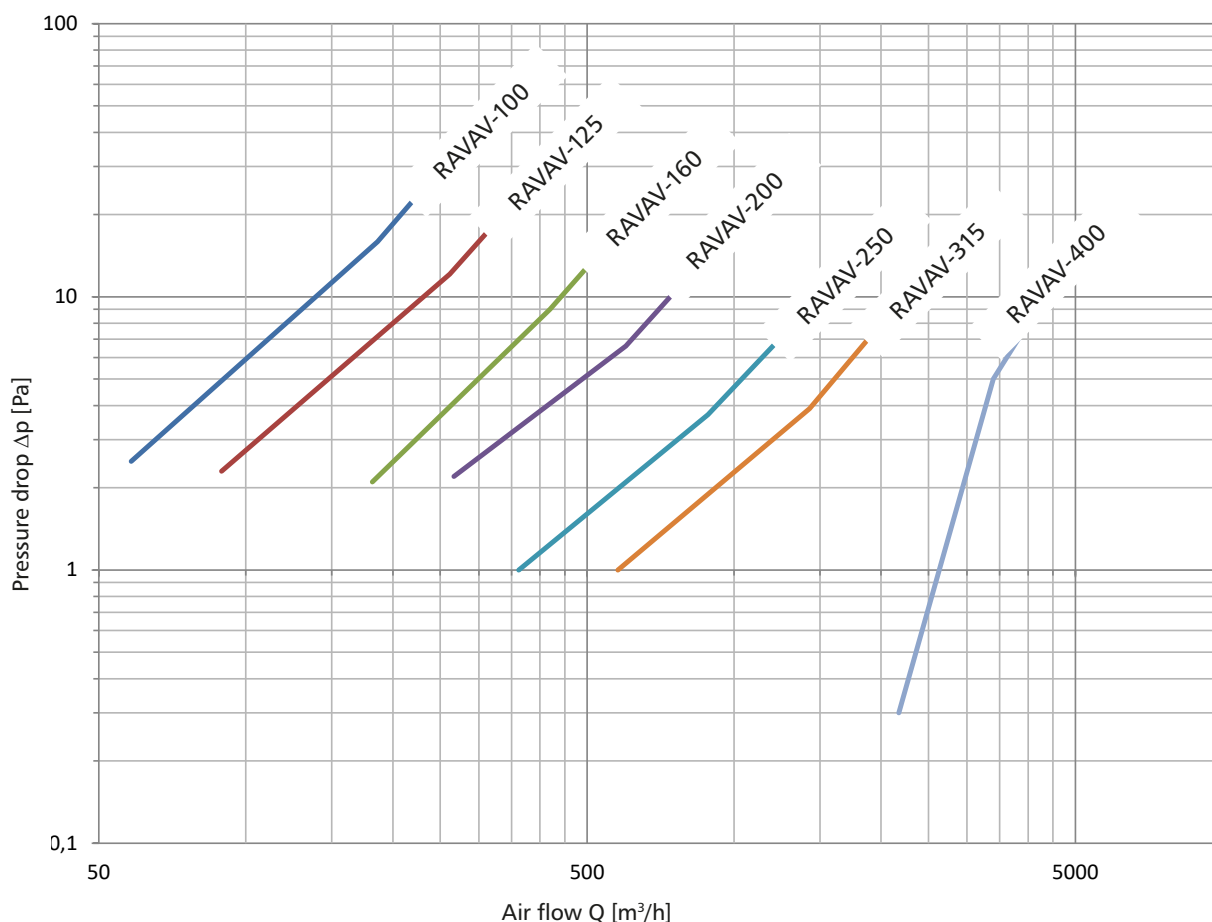

Pressure drop in RAVAV regulator with fully opened damper

Standard air flows of the RAVAV regulator

DN	Air flow [m³/h]		
	min. (2 [m/s])	max. (12 [m/s])	nom. (12 [m/s])
100	53	316	316
125	83	501	501
150	121	728	728
160	139	831	831
200	218	1309	1309
250	342	2053	2053
300	495	2971	2971
315	546	3277	3277
355	695	4173	4173
400	884	5305	5305
500	1386	8314	8314
630	2209	13254	13254

VAV flow regulator

RAVAV

Pressure drops

Pressure drop and level of sound power emitted to the system for different damper settings

DN	v [m/s]	q [m³/h] [l/s]			$\alpha = 15^\circ$										$\alpha = 30^\circ$											
					Δp [Pa]	L_w [dB/Okt]								L_w [dB]	L_{vva} [dB(A)]	Δp [Pa]	L_w [dB/Okt]								L_w [dB]	L_{vva} [dB(A)]
						f_m [Hz]											f_m [Hz]									
						63	125	250	500	1000	2000	4000	8000				63	125	250	500	1000	2000	4000	8000		
100	2	53	15	3	0	0	0	-1	-1	-8	-15	-23	7	2	10	8	8	8	8	8	4	-4	-11	15	11	
	4	105	29	14	18	18	18	18	17	17	10	3	26	23	39	27	27	26	26	26	22	15	34	31		
	6	158	44	30	29	29	29	28	28	28	26	18	37	34	87	37	29	29	28	28	28	26	18	40	34	
	8	211	59	54	37	36	36	36	36	36	35	28	45	42	155	45	45	45	44	44	44	44	40	53	51	
	10	263	73	85	42	42	42	42	42	41	41	37	50	48	242	51	51	50	50	50	50	50	49	59	57	
	12	316	88	122	47	47	47	47	46	46	46	44	55	53	348	56	55	55	55	55	55	54	54	64	62	
125	2	83	23	3	2	2	2	1	0	-8	-16	-24	8	3	10	10	10	10	10	10	4	-4	-12	17	13	
	4	167	46	14	20	20	20	20	19	18	10	2	27	24	39	29	28	28	28	28	22	14	36	33		
	6	250	70	30	31	31	30	30	30	30	25	17	38	35	87	39	39	39	39	39	38	37	29	47	44	
	8	334	93	54	38	38	38	38	38	37	36	28	46	43	155	39	39	39	39	39	38	37	29	47	44	
	10	417	116	85	44	44	44	44	44	43	43	36	52	50	242	53	53	52	52	52	52	52	48	61	58	
	12	501	139	122	49	49	49	49	48	48	48	43	57	55	348	58	57	57	57	57	57	56	55	66	63	
160	2	139	38	3	4	4	4	3	-1	-9	-17	-24	10	4	10	13	12	12	12	11	3	-5	-12	19	14	
	4	277	77	14	22	22	22	22	22	17	9	2	29	25	39	31	31	30	30	30	29	21	13	38	35	
	6	416	115	30	33	33	33	32	32	32	24	17	40	37	87	41	41	41	41	41	40	36	29	49	46	
	8	554	154	54	41	40	40	40	40	40	35	27	48	45	155	49	49	49	48	48	48	47	39	57	54	
	10	693	192	85	46	46	46	46	46	45	43	36	54	51	242	55	55	55	54	54	54	54	48	63	60	
	12	831	231	122	51	51	51	51	50	50	50	42	59	57	348	60	60	59	59	59	59	58	54	68	65	
200	2	218	61	3	6	6	6	5	-1	-9	-17	-25	12	5	10	14	14	14	14	10	3	-5	-13	21	15	
	4	436	121	14	24	24	24	24	23	19	11	3	31	27	39	33	32	32	32	32	29	21	13	40	36	
	6	654	182	30	35	35	35	34	34	32	24	16	42	38	87	43	43	43	43	43	42	36	28	51	48	
	8	872	242	54	43	42	42	42	42	41	35	27	50	47	155	51	51	51	50	50	50	47	39	59	56	
	10	1091	303	85	48	48	48	48	48	47	43	35	56	53	242	57	57	56	56	56	56	55	47	65	62	
	12	1309	364	122	53	53	53	53	52	52	50	42	61	58	348	62	61	61	61	61	61	60	54	70	67	
250	2	342	95	3	8	8	7	6	-2	-10	-18	-25	13	5	10	16	16	16	16	10	2	-6	-13	22	16	
	4	684	190	14	26	26	26	26	24	16	8	0	33	27	39	35	34	34	34	34	28	20	12	41	37	
	6	1027	285	30	37	37	36	36	36	31	23	16	44	39	87	45	45	45	45	44	43	35	28	52	49	
	8	1369	380	54	44	44	44	44	44	42	34	26	52	48	155	53	53	52	52	52	52	46	38	60	57	
	10	1711	475	85	50	50	50	50	49	49	42	35	58	55	242	59	59	58	58	58	58	54	47	66	63	
	12	2053	570	122	55	55	55	54	54	54	49	41	63	60	348	64	63	63	63	63	62	61	53	71	69	
315	2	546	152	3	10	10	9	5	-3	-10	-18	-26	15	6	10	18	18	18	17	9	2	-6	-14	24	17	
	4	1092	303	14	28	28	28	27	23	15	8	0	34	28	39	37	36	36	36	35	27	20	12	43	38	
	6	1639	455	30	39	39	38	38	38	31	23	15	46	41	87	47	47	47	47	46	43	35	27	54	50	
	8	2185	607	54	46	46	46	46	46	41	34	26	53	49	155	55	55	54	54	54	53	45	38	62	59	
	10	2731	759	85	52	52	52	52	51	50	42	34	59	56	242	61	60	60	60	60	60	54	46	68	65	
	12	3277	910	122	57	57	57	56	56	56	49	41	64	61	348	66	65	65	65	65	64	61	53	73	70	
400	2	884	246	3	12	12	11	5	-3	-11	-19	-27	17	6	10	20	20	20	17	9	1	-7	-15	26	17	
	4	1768	491	14	30	30	30	29	23	15	7	-1	36	29	39	39	38	38	38	35	27	19	11	45	39	
	6	2652	737	30	41	41	40	40	38	30	22	14	47	42	87	49	49	49	49	48	42	34	26	56	51	
	8	3536	982	54	48	48	48	48	48	41	33	25	55	51	155	57	57	56	56	56	53	45	37	64	60	
	10	4420	1228	85	54	54	54	54	53	49	41	33	61	57	242	63	63	62	62	62	61	53	45	70	67	
	12	5305	1473	122	59	59	59	58	58	56	48	40	66	62	348	68	67	67	67	67	66	60	52	75	72	

VAV flow regulator

RAVAV

Pressure drops

Pressure drop and level of sound power emitted to the system for different damper settings

DN	v			q			$\alpha = 45^\circ$							$\alpha = 60^\circ$											
							Δp	L_w [dB/Okt]						L_w [dB]	L_{WA} [dB(A)]	Δp	L_w [dB/Okt]						L_w [dB]	L_{WA} [dB(A)]	
	[Pa]	f_m [Hz]						[Pa]	f_m [Hz]																
		[m/s]	[m³/h]	[l/s]	63	125	250		500	1000	2000	4000	8000	63	125	250	500	1000	2000	4000	8000				
100	2	53	15	41	19	19	18	18	18	18	11	3	26	23	206	33	33	33	33	33	32	32	24	41	39
	4	105	29	165	37	37	37	36	36	36	36	29	45	43	823	52	51	51	51	51	51	50	50	60	58
	6	158	44	370	48	48	47	47	47	47	47	44	56	53	1851	62	48	47	47	47	47	47	44	63	54
	8	211	59	658	55	55	55	55	55	54	54	54	64	61	3291	70	70	70	69	69	69	69	68	78	76
	10	263	73	1029	61	61	61	61	60	60	60	60	70	67	5143	76	76	75	75	75	75	75	74	84	82
	12	316	88	1481	66	66	66	65	65	65	65	65	74	72	7405	81	80	80	80	80	80	80	79	79	89
125	2	83	23	41	21	21	20	20	20	18	11	3	28	24	206	35	35	35	35	35	34	31	23	43	40
	4	167	46	165	39	39	39	38	38	38	36	29	47	44	823	54	53	53	53	53	53	52	49	62	59
	6	250	70	370	50	49	49	49	49	49	48	44	58	55	1851	64	64	64	64	63	63	63	63	73	70
	8	334	93	658	57	57	57	57	56	56	56	55	65	63	3291	64	64	64	64	63	63	63	63	73	70
	10	417	116	1029	63	63	63	63	62	62	62	62	71	69	5143	78	78	77	77	77	77	77	76	86	84
	12	501	139	1481	68	68	68	67	67	67	67	67	76	74	7405	83	82	82	82	82	82	82	81	81	91
160	2	139	38	41	23	23	22	22	22	18	10	2	30	26	206	37	37	37	37	37	36	31	23	45	42
	4	277	77	165	41	41	41	41	40	40	36	28	49	46	823	56	56	55	55	55	55	54	49	64	61
	6	416	115	370	52	52	51	51	51	51	51	43	60	57	1851	66	66	66	66	66	65	65	64	75	72
	8	554	154	658	59	59	59	59	59	58	58	54	67	65	3291	74	74	74	73	73	73	73	73	82	80
	10	693	192	1029	65	65	65	65	64	64	64	62	73	71	5143	80	80	79	79	79	79	79	78	88	86
	12	831	231	1481	70	70	70	69	69	69	69	69	78	76	7405	85	84	84	84	84	84	84	83	83	93
200	2	218	61	41	25	25	24	24	24	17	10	2	32	27	206	39	39	39	39	39	38	30	22	47	43
	4	436	121	165	43	43	43	42	42	42	38	30	51	48	823	58	57	57	57	57	57	56	48	66	63
	6	654	182	370	54	54	53	53	53	53	50	43	61	59	1851	68	68	68	68	67	67	67	63	76	74
	8	872	242	658	61	61	61	61	60	60	60	53	69	67	3291	76	76	75	75	75	75	75	74	84	82
	10	1091	303	1029	67	67	67	67	66	66	66	62	75	73	5143	82	82	81	81	81	81	81	80	90	88
	12	1309	364	1481	72	72	72	71	71	71	71	69	80	78	7405	87	86	86	86	86	86	86	85	85	95
250	2	342	95	41	27	26	26	26	25	17	9	1	33	28	206	41	41	41	41	40	37	30	22	48	44
	4	684	190	165	45	45	45	44	44	43	35	27	52	49	823	60	59	59	59	59	58	55	48	67	64
	6	1027	285	370	56	55	55	55	55	55	50	42	63	60	1851	70	70	70	70	69	69	69	63	78	76
	8	1369	380	658	63	63	63	63	62	62	61	53	71	68	3291	78	78	77	77	77	77	77	74	86	83
	10	1711	475	1029	69	69	69	68	68	68	68	61	77	75	5143	84	83	83	83	83	83	82	82	92	90
	12	2053	570	1481	74	74	73	73	73	73	73	68	82	79	7405	88	88	88	88	88	87	87	87	87	97
315	2	546	152	41	29	28	28	28	24	16	8	1	35	29	206	43	43	43	43	42	37	29	21	50	46
	4	1092	303	165	47	47	46	46	46	42	34	26	54	50	823	61	61	61	61	61	60	55	47	69	66
	6	1639	455	370	58	57	57	57	57	57	49	42	65	62	1851	72	72	72	72	71	71	70	62	80	77
	8	2185	607	658	65	65	65	65	64	64	60	52	73	70	3291	80	80	79	79	79	79	79	73	88	85
	10	2731	759	1029	71	71	71	70	70	70	68	61	79	76	5143	86	85	85	85	85	85	84	81	94	91
	12	3277	910	1481	76	76	75	75	75	75	75	67	84	81	7405	90	90	90	90	90	89	89	88	88	99
400	2	884	246	41	31	30	30	30	23	16	8	0	37	30	206	45	45	45	45	44	36	28	21	52	47
	4	1768	491	165	49	49	48	48	48	41	34	26	56	51	823	64	63	63	63	63	62	54	47	71	68
	6	2652	737	370	60	59	59	59	59	57	49	41	67	63	1851	74	74	74	74	73	73	69	62	82	79
	8	3536	982	658	67	67	67	67	66	66	60	52	75	71	3291	82	82	81	81	81	81	80	72	90	87
	10	4420	1228	1029	73	73	73	72	72	72	68	60	81	78	5143	88	87	87	87	87	87	86	81	96	93
	12	5305	1473	1481	78	78	77	77	77	77	75	67	86	83	7405	92	92	92	92	92	91	91	88	101	98

VAV flow regulator

RAVAV

Servomotor specification

RAVAV regulators are supplied with the Belimo Compact control mechanism with standard running times, where the operating parameters are set at the stage of regulator calibration by the manufacturer. Technical data of servomotors:

Symbol	LMV-D3-MP	NMV-D3-MP
Nominal voltage	24 V AC, 50/60 Hz 24 V DC	
Operating range	19,2 ... 28,8 V AC 21,6 ... 28,8 V DC	
Nominal power	4 VA (max 8 A for 5 ms)	5 VA (max 8 A for 5 ms)
Power consumption	2 W	3 W
Resistance class	III (safe voltage - low)	
Insulation class	IP54	
Electromagnetic compatibility	CE acc. to 89/336/EEC	
Ambient temperature	0 ... +50°C	
Ambient humidity	5 ... 95% relative humidity, no condensation (as per EN 60730-1)	
Maintenance	maintenance-free	
Standard control		
VAV mode with Y lead signal (terminal 3)	2 ... 10 V DC / (4 ... 20 mA with 500 Ω resistor), min input impedance 100 kΩ	
	0 ... 10 V DC / (0 ... 20 mA with 500 Ω resistor), min input impedance 100 kΩ	
	possible settings 0 ... 10 V DC, min input impedance 100 kΩ	
Operating mode for measuring signal U5 (terminal 5)	2 ... 10 V DC, max 0,5 mA	
	0 ... 10 V DC, max 0,5 mA	
	adjustable: volumetric flow, damper position or differential pressure, max 0,5 mA	
CAV operating modes	CLOSED / Vmin. / (Vav. *) / Vmax / OPEN * (* only with 24 V AC power supply)	
MP bus functions		
Bus address	MP1 ... 8 (standard operation: PP)	
EIB-Konnex / MODBUS RTU / BACnet	with BELIMO UK24EIB / UK24MOD / UK24BAC, 1 to 8 Belimo MP devices (VAV regulator / damper or valve servomotor)	
DDC regulator	DDC regulator / PLC with integral MP bus interface, various manufacturers	
Adjusting ventilator speed	with BELIMO COU24-A-MP regulator	
Connecting the sensor	passive (PT1000, Ni1000, etc.) and active sensor with 0...10 V input signal, e.g. temperature, humidity sensor	
	two-state signal (contact load capacity 16 mA / 24V) e.g. switches, presence sensors	

It is also possible to provide regulators with actuators integrated for KNX, MODBUS communication.

VAV flow regulator

RAVAV

Connections diagram

VAV – analogue reference signa:

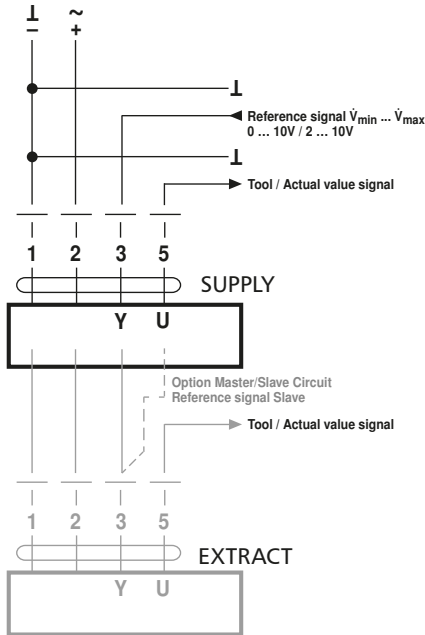

VAV – with shutt-off (closed), 2 ... 10V mode:

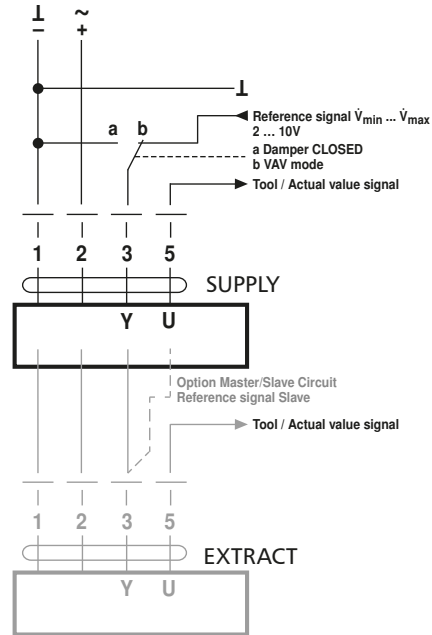

Damper CLOSED via 0 ... 10 V reference signal
(Mode 2 ... 10 V)

Function	Standard: 0,1V	Shut-off level: 0,5 V
Damper CLOSED	< 0,1V	< 0,5V
V_{min}	> 0,1 ... 2V	> 0,5 ... 2V
$V_{min} ... V_{max}$	2 ... 10V	2 ... 10V

CAV - step mode CLOSED / V_{min} / V_{mid} / V_{max} / OPEN

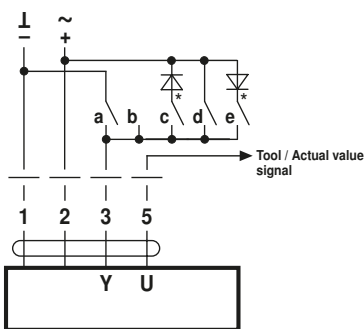

CAV Function CLOSED – V_{min} – V_{max} – OPEN
(standard)

	a	b	c	d	e
Signal	\perp		\sim	\sim	\sim
Switching terminal 3	$\frac{\perp}{3}$	$\frac{\perp}{3}$	$\frac{\sim}{3}$	$\frac{\sim}{3}$	$\frac{\sim}{3}$
Mode 2 ... 10 V	CLOSED	V_{min}	CLOSED *	V_{max}	OPEN *
Mode 0 ... 10 V	V_{min}	V_{min}	CLOSED *	V_{max}	OPEN *

PC-Tool "CAV Function" setting:
2 ... 10 V, Shut-off level 0.1 V

PC-Tool "CAV Function" setting:
CLOSED – V_{min} – V_{max} . Shut-off level CLOSED: 0.1 V

CAV function CLOSED – V_{min} – V_{mid} – V_{max} – OPEN

	a	b	c	d	e
Signal	\perp		\sim	\sim	\sim
Switching terminal 3	$\frac{\perp}{3}$	$\frac{\perp}{3}$	$\frac{\sim}{3}$	$\frac{\sim}{3}$	$\frac{\sim}{3}$
Mode 2 ... 10 V	CLOSED	V_{min}	V_{mid} *	V_{max}	OPEN *
Mode 0 ... 10 V	V_{min}	V_{min}	V_{mid} *	V_{max}	OPEN *

PC-Tool "CAV Function" setting:
CLOSED – V_{min} – V_{mid} – V_{max} (NMV-D2M compatible)

Note!

- Note that the contacts are mutually interlocking.
- DC supply: C and E are not available with DC 24 V

VAV flow regulator

RAVAV

RAVAV-G regulators are supplied with 227VM-024-05 (227VM-024-10) servomotors, where the operating parameters are preset at the stage of regulator calibration by the manufacturer. It is possible to adjust the settings without additional tools, after the regulator is installed in the system. Technical data of servomotors:

Symbol	227VM-024-05	227VM-024-10
Nominal voltage	24V AC/DC	
Operating range	19 ... 29V AC/DC	
Power consumption	2,5W (operation), 1,0 (standby)	2,5 W (operation), 1,5 W (standby)
Resistance class	III (safe voltage - low)	
Casing insulation class	IP42	
Electromagnetic compatibility	CE (2004/108/EG)	
Ambient temperature	0 ... +50°C	
Ambient humidity	5 ... 95% % relative humidity, no condensation (as per EN 60730-1)	
Maintenance	maintenance-free	

Connection diagram RAVAV-G

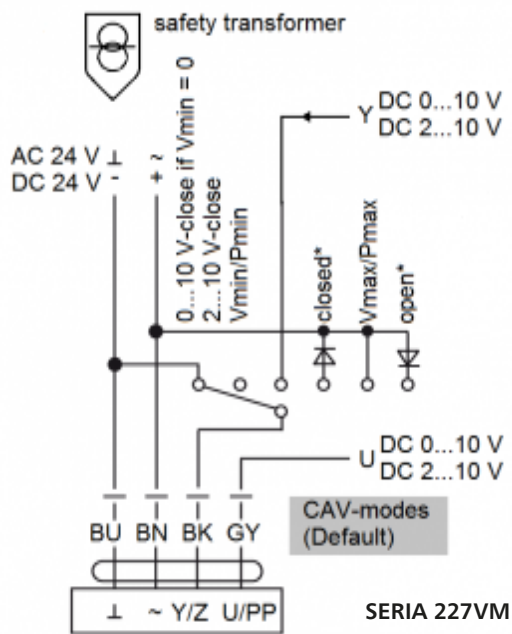

Servomotor user manual



Front panel:

1. Disengagement button (self-restoring)
2. Value selection knob
3. Function selection knob
4. Display

The manual refers to the operation of RAVAV-G regulator servomotor (series 227VM)

The display shows values in accordance with selected function. Apart from digital values, the square symbols located by the display right edge indicate the active flow unit (m³/h or l/s) of selected diagnostic function.

A specific function is selected using the function selection knob (3), and values for specific functions are selected using the value selection knob (2).

If no function is selected, the display will show three horizontal dashes (- - -).

After setting a desired value, its saving is confirmed with double blink of the displayed symbols.

Function selection:

1.FLOW function

Current flow in m³/h or l/s is displayed. The displayed value is consistent with the value of measurement signal U (2-10 VDC or 0-10 VDC). By turning the value selection knob, it is possible to choose between flow units (m³/h or l/s).

2.Vmin function

It enables to set the required minimum flow for the external lead signal Y=0 V or Y=2 V. By turning the value selection knob, it is possible to set the required V_{min}.

3.Vmax function

It enables to set the required maximum flow for the external lead signal Y=10 V. By turning the value selection knob, it is possible to set the required V_{max}.

4.MODE function

It enables to set the rotation direction (clockwise or counterclockwise) and the input range (0-10 V or 2-10 VDC) for lead signal Y. The range of measurement signal U corresponds to lead signal Y.

- 0 - n - 0-10 V, clockwise (CW)
- 0 - i - 0-10 V, counterclockwise (CCW)
- 2 - n - 2-10 V, clockwise (CW)
- 2 - i - 2-10 V, counterclockwise (CCW)

5.DIAG function

It activates the diagnostic menu. The external lead signal Y is omitted, actions are performed in accordance with the function chosen using the value selection knob. Diagnostic functions are automatically deactivated after 10 hours. In the Diag mode, the display blinks, showing the current flow for 8 seconds and the selected function for 2 seconds.

- **oP** full opening of damper
- **cL** full closing of damper
- **Hi** forcing of V_{max}
- **Lo** forcing of V_{min}
- **on** test mode ON – servomotor remains in current position
- **oFF** test mode OFF – servomotor operates in line with the external lead signal Y (the signal is presented as 0 – 100 x 10⁻¹ V)

6.Vnom function

It enables to set the V_{nom} value (nominal flow) which corresponds to the differential pressure of 86 Pa measured at the metering system (or another value depending on the maximum speed of air flow through the regulator). The value is factory-set and adjusted by the regulator manufacturer during calibration.